



VANTAGE FENCE

STEEL FENCE WHOLESAL SUPPLIER



VANTAGE POWDER COATING PROCESS

17 - Step Immersion Pre-Treatment + Epoxy Process + Top Powder Coat

PRE-TREATMENT



ALKALINE
SPRAY WASH



ALKALINE
IMMERSION



WATER
IMMERSION

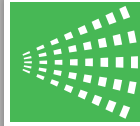

SPRAY
CONDITIONER



PHOSPHATE
IMMERSION



WATER
IMMERSION



SAND
BLAST

EPOXY PROCESS



ELECTRO COAT
EPOXY PRIMER



PERMEATE
SPRAY RINSE



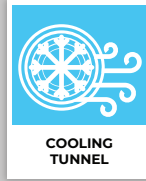

TOP POWDER COAT

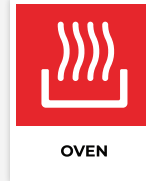
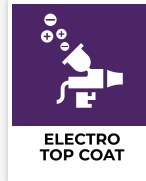

2 - RAIL COMMERCIAL

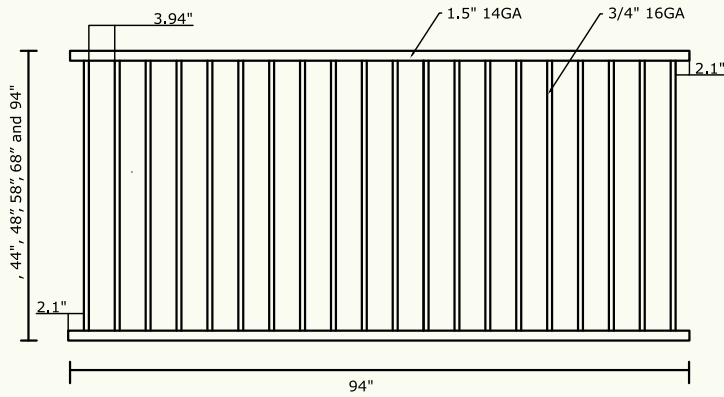

2 - RAIL COM FLAT TOP PANELS - CARNEGIE

CODE	DESCRIPTION
COM 2R FTB 38" x 94" BLK	Rails: 1.5" x 1.5" 14GA Pickets: 3/4" x 3/4" 16GA Gap: 4"
COM 2R FTB 44" x 94" BLK	Rails: 1.5" x 1.5" 14GA Pickets: 3/4" x 3/4" 16GA Gap: 4"
COM 2R FTB 48" x 94" BLK	Rails: 1.5" x 1.5" 14GA Pickets: 3/4" x 3/4" 16GA Gap: 4"
COM 2R FTB 58" x 94" BLK	Rails: 1.5" x 1.5" 14GA Pickets: 3/4" x 3/4" 16GA Gap: 4"
COM 2R FTB 68" x 94" BLK	Rails: 1.5" x 1.5" 14GA Pickets: 3/4" x 3/4" 16GA Gap: 4"
COM 2R FTB 94" x 94" BLK	Rails: 1.5" x 1.5" 14GA Pickets: 3/4" x 3/4" 16GA Gap: 4"

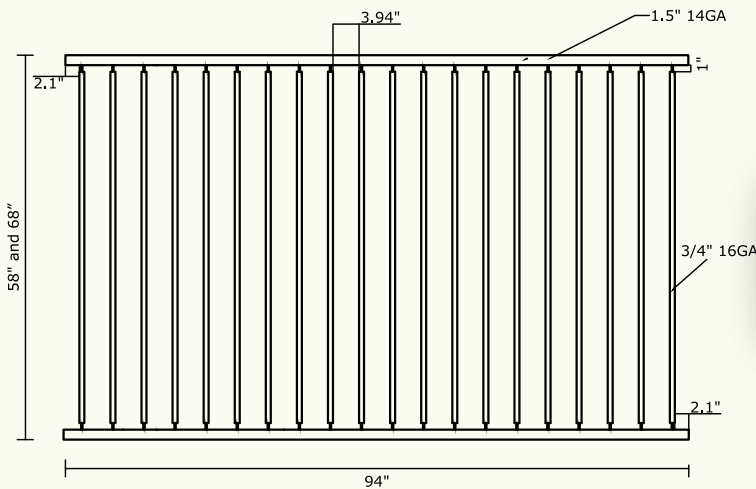

2 - RAIL COM FLAT TOP BIAS PANELS - RICHMOND

CODE	DESCRIPTION
COM 2R FTB 58" x 94" BLK	Rails: 1.5" x 1.5" 14GA Pickets: 3/4" x 3/4" 16GA Gap: 4"
COM 2R FTB 68" x 94" BLK	Rails: 1.5" x 1.5" 14GA Pickets: 3/4" x 3/4" 16GA Gap: 4"



2 - RAIL COMMERCIAL

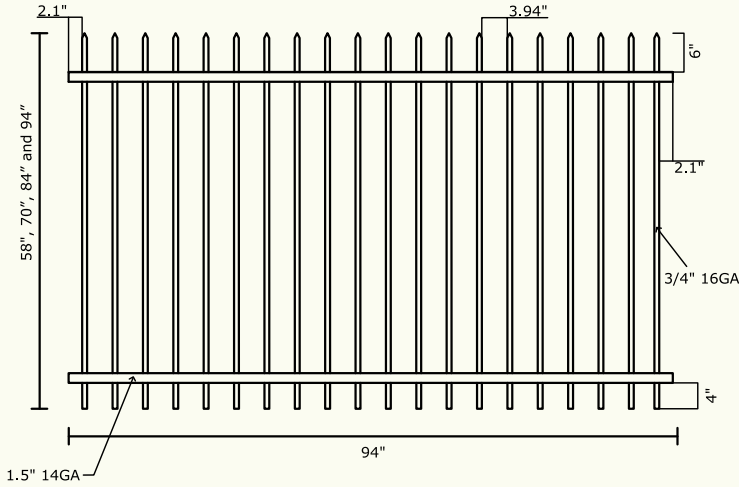

2 - RAIL COM PINCH SPEAR PANELS - SORRENTO

CODE	DESCRIPTION
COM 2R PIN 58" x 94" BLK	Rails: 1.5" x 1.5" 14GA Pickets: 3/4" x 3/4" 16GA Gap: 4"
COM 2R PIN 70" x 94" BLK	Rails: 1.5" x 1.5" 14GA Pickets: 3/4" x 3/4" 16GA Gap: 4"
COM 2R PIN 84" x 94" BLK	Rails: 1.5" x 1.5" 14GA Pickets: 3/4" x 3/4" 16GA Gap: 4"
COM 2R PIN 94" x 94" BLK	Rails: 1.5" x 1.5" 14GA Pickets: 3/4" x 3/4" 16GA Gap: 4"

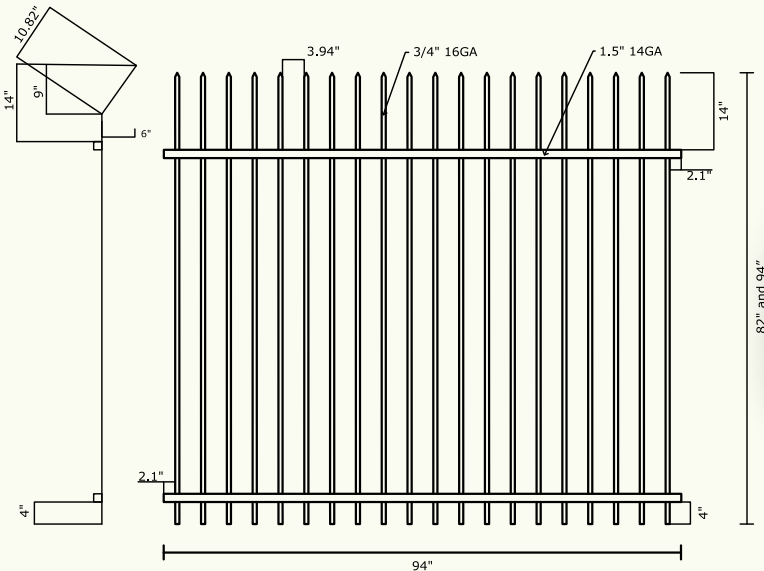

2 - RAIL COM CURVE TOP PANELS - BRUNSWICK

CODE	DESCRIPTION
COM 2R CURVE PIN 82" x 94" BLK	Rails: 1.5" x 1.5" 14GA Pickets: 3/4" x 3/4" 16GA Gap: 4"
COM 2R CURVE PIN 94" x 94" BLK	Rails: 1.5" x 1.5" 14GA Pickets: 3/4" x 3/4" 16GA Gap: 4"



2 - RAIL RESIDENTIAL

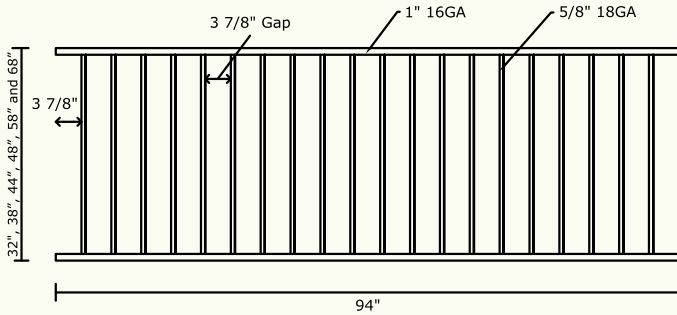

2 - RAIL RESIDENTIAL FLAT TOP PANELS

CODE	DESCRIPTION
RES 2R FTB 32" x 94" BLK	Rails: 1" x 1" 16GA Pickets: 5/8" x 5/8" 18GA Gap: 3 7/8"
RES 2R FTB 38" x 94" BLK	Rails: 1" x 1" 16GA Pickets: 5/8" x 5/8" 18GA Gap: 3 7/8"
RES 2R FTB 44" x 94" BLK	Rails: 1" x 1" 16GA Pickets: 5/8" x 5/8" 18GA Gap: 3 7/8"
RES 2R FTB 48" x 94" BLK	Rails: 1" x 1" 16GA Pickets: 5/8" x 5/8" 18GA Gap: 3 7/8"
RES 2R FTB 58" x 94" BLK	Rails: 1" x 1" 16GA Pickets: 5/8" x 5/8" 18GA Gap: 3 7/8"
RES 2R FTB 68" x 94" BLK	Rails: 1" x 1" 16GA Pickets: 5/8" x 5/8" 18GA Gap: 3 7/8"

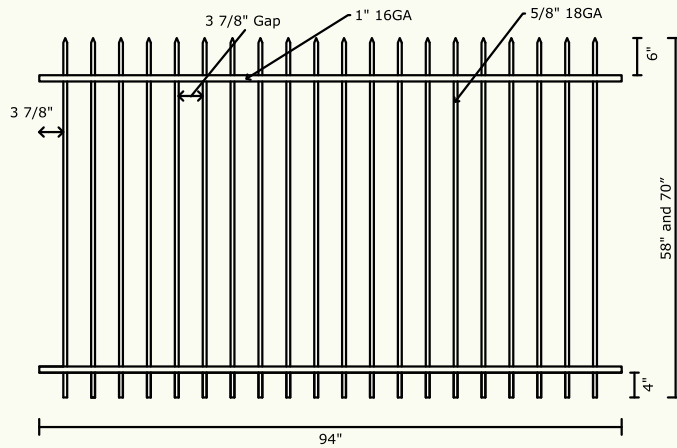

2 - RAIL RESIDENTIAL PINCH SPEAR PANELS

CODE	DESCRIPTION
RES 2R PIN 58" x 94" BLK	Rails: 1" x 1" 16GA Pickets: 5/8" x 5/8" 18GA Gap: 3 7/8"
RES 2R PIN 70" x 94" BLK	Rails: 1" x 1" 16GA Pickets: 5/8" x 5/8" 18GA Gap: 3 7/8"

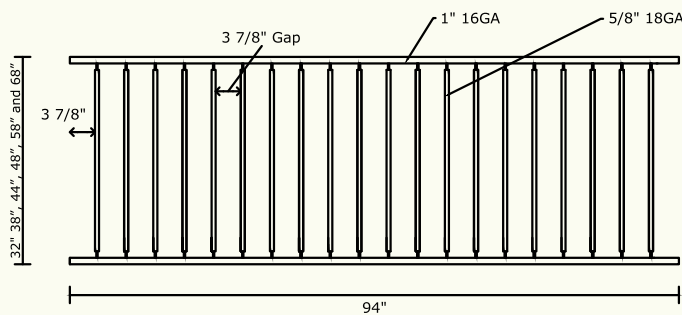

2 - RAIL RESIDENTIAL FLAT TOP PANELS

CODE	DESCRIPTION
RES 2R FTP 32" x 94" BLK	Rails: 1" x 1" 16GA Pickets: 5/8" x 5/8" 18GA Gap: 3 7/8"
RES 2R FTP 38" x 94" BLK	Rails: 1" x 1" 16GA Pickets: 5/8" x 5/8" 18GA Gap: 3 7/8"
RES 2R FTP 44" x 94" BLK	Rails: 1" x 1" 16GA Pickets: 5/8" x 5/8" 18GA Gap: 3 7/8"
RES 2R FTP 48" x 94" BLK	Rails: 1" x 1" 16GA Pickets: 5/8" x 5/8" 18GA Gap: 3 7/8"
RES 2R FTP 58" x 94" BLK	Rails: 1" x 1" 16GA Pickets: 5/8" x 5/8" 18GA Gap: 3 7/8"
RES 2R FTP 68" x 94" BLK	Rails: 1" x 1" 16GA Pickets: 5/8" x 5/8" 18GA Gap: 3 7/8"



3 - RAIL COMMERCIAL

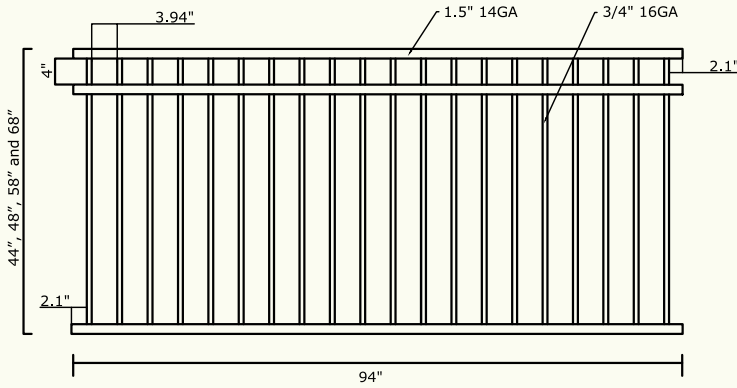

3 - RAIL COM FLAT TOP PANELS - CARNEGIE

CODE	DESCRIPTION
COM 3R FTB 44" x 94" BLK	Rails: 1.5" x 1.5" 14GA Pickets: 3/4" x 3/4" 16GA Gap: 4"
COM 3R FTB 48" x 94" BLK	Rails: 1.5" x 1.5" 14GA Pickets: 3/4" x 3/4" 16GA Gap: 4"
COM 3R FTB 58" x 94" BLK	Rails: 1.5" x 1.5" 14GA Pickets: 3/4" x 3/4" 16GA Gap: 4"
COM 3R FTB 68" x 94" BLK	Rails: 1.5" x 1.5" 14GA Pickets: 3/4" x 3/4" 16GA Gap: 4"

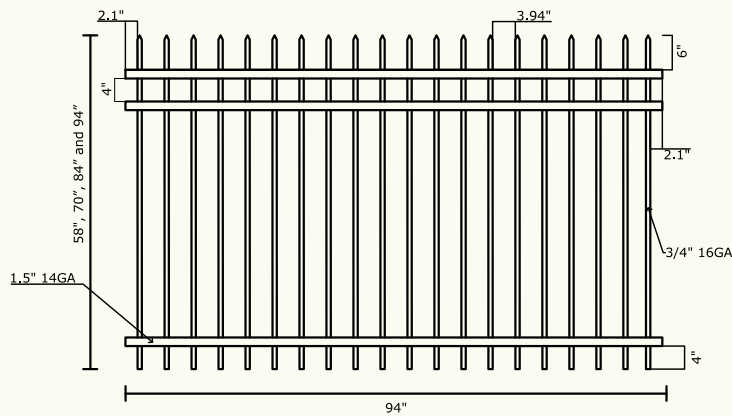

3 - RAIL COM PINCH SPEAR PANELS - SORRENTO

CODE	DESCRIPTION
COM 3R PIN 58" x 94" BLK	Rails: 1.5" x 1.5" 14GA Pickets: 3/4" x 3/4" 16GA Gap: 4"
COM 3R PIN 70" x 94" BLK	Rails: 1.5" x 1.5" 14GA Pickets: 3/4" x 3/4" 16GA Gap: 4"
COM 3R PIN 84" x 94" BLK	Rails: 1.5" x 1.5" 14GA Pickets: 3/4" x 3/4" 16GA Gap: 4"
COM 3R PIN 94" x 94" BLK	Rails: 1.5" x 1.5" 14GA Pickets: 3/4" x 3/4" 16GA Gap: 4"

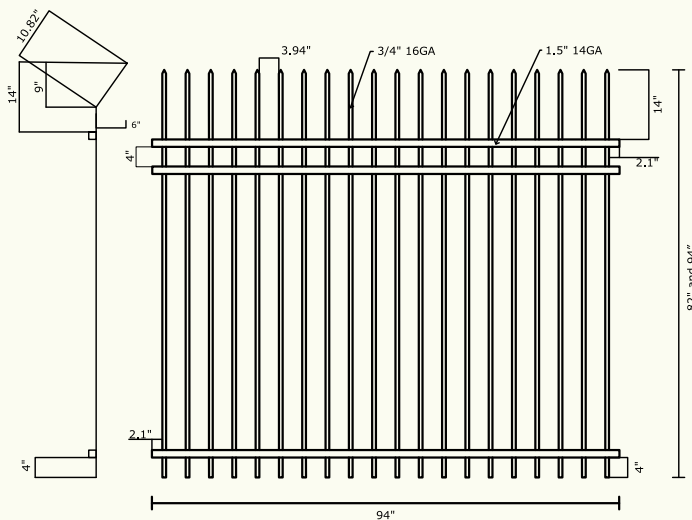

3 - RAIL COM CURVE TOP PANELS - BRUNSWICK

CODE	DESCRIPTION
COM 3R CURVE PIN 82" x 94" BLK	Rails: 1.5" x 1.5" 14GA Pickets: 3/4" x 3/4" 16GA Gap: 4"
COM 3R CURVE PIN 94" x 94" BLK	Rails: 1.5" x 1.5" 14GA Pickets: 3/4" x 3/4" 16GA Gap: 4"

3 - RAIL RESIDENTIAL

3 - RAIL RESIDENTIAL FLAT TOP PANELS

CODE	DESCRIPTION
RES 3R FTB 32" x 94" BLK	Rails: 1" x 1" 16GA Pickets: 5/8" x 5/8" 18GA Gap: 3 7/8"
RES 3R FTB 38" x 94" BLK	Rails: 1" x 1" 16GA Pickets: 5/8" x 5/8" 18GA Gap: 3 7/8"
RES 3R FTB 44" x 94" BLK	Rails: 1" x 1" 16GA Pickets: 5/8" x 5/8" 18GA Gap: 3 7/8"
RES 3R FTB 58" x 94" BLK	Rails: 1" x 1" 16GA Pickets: 5/8" x 5/8" 18GA Gap: 3 7/8"
RES 3R FTB 68" x 94" BLK	Rails: 1" x 1" 16GA Pickets: 5/8" x 5/8" 18GA Gap: 3 7/8"

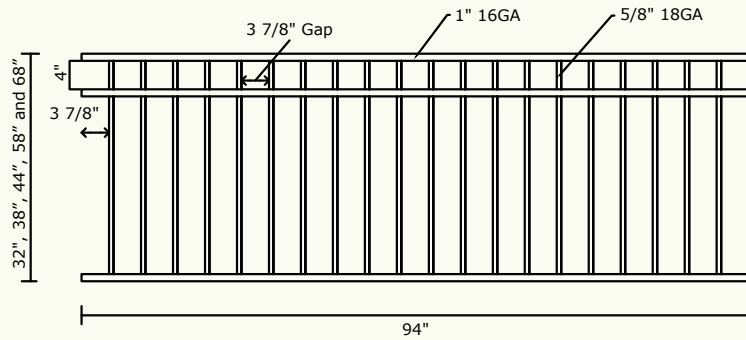

BRIGHTON

3 - RAIL RESIDENTIAL PINCH SPEAR PANELS

CODE	DESCRIPTION
RES 3R PIN 58" x 94" BLK	Rails: 1" x 1" 16GA Pickets: 5/8" x 5/8" 18GA Gap: 3 7/8"
RES 3R PIN 70" x 94" BLK	Rails: 1" x 1" 16GA Pickets: 5/8" x 5/8" 18GA Gap: 3 7/8"

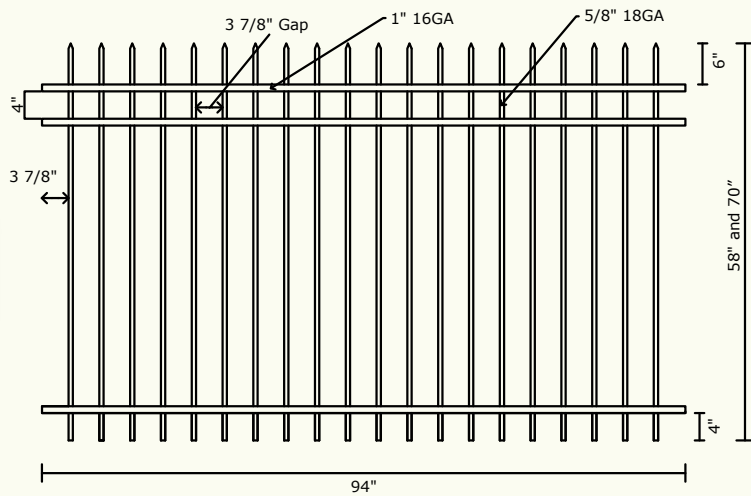

PRESTON

EXPANDED METAL AND PERFORATED METAL

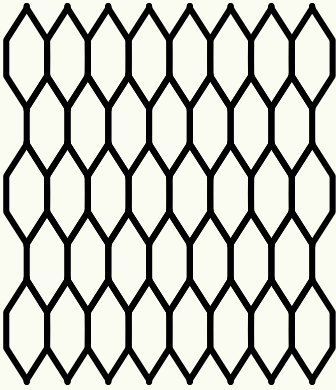

- Flattened
- 1/2" diamond
- 16GA



- Flattened
- 1/2" diamond
- 13 GA

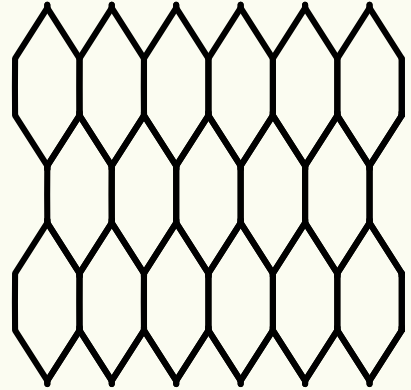

- Flattened
- 3/4" diamond
- 9GA

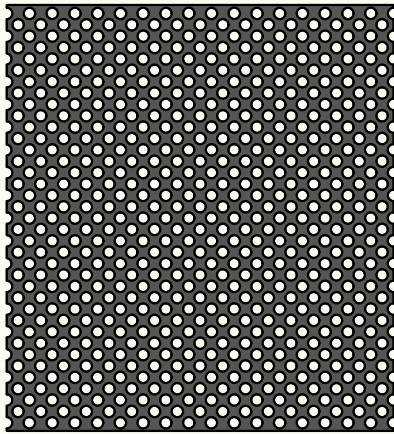

- Small hole - 1/16"
- 1/8" Staggered centers
- 24GA



- Large hole - 3/32"
- 3/16" Staggered centers
- 24GA

EXPANDED METAL/POWDER COATED BLACK

DIAMOND + GAUGE	Wt. (lbs.)	Sheet Size
1/2" + 16GA	27.5	48" X 96"
1/2" + 13GA	47.5	48" X 96"
3/4" + 9GA	57.6	48" X 96"

PERFORATED METAL/POWDER-COATED BLACK

STYLE	Wt. (lbs.)	Sheet Size
Small Hole	18.8	36" X 84"
Small Hole	25.0	48" X 84"
Large Hole	16.1	36" X 84"
Large Hole	21.8	48" X 84"

POWDER COATED BLACK POSTS W/ CAP

14 GA POSTS

CODE	QTY
1" x 14 GA x 60" (5') BK	70
1" x 14GA x 72" (6') BK	70
1" x 14GA x 84" (7') BK	70
1.5" x 14GA x 72" (6') BK	70
1.5" x 14GA x 96" (8') BK	70
2" x 14GA x 72" (6') BK	70
2" x 14GA x 84" (7') BK	70
2" x 14GA x 96" (8') BK	70
2" x 14GA x 108" (9') BK	70
2" x 14GA x 120" (10') BK	70
3" x 3" x 14GA x 98" (8') BK	35
3" x 3" x 14GA x 114" (9.5') BK	35
3" x 3" x 14GA x 126" (10.5') BK	35
3" x 3" x 14GA x 138" (11.5') BK	35
4" x 4" x 14GA x 98" (8') BK	20
4" x 4" x 14GA x 114" (9.5') BK	20
4" x 4" x 14GA x 126" (10.5') BK	20
4" x 4" x 14GA x 138" (11.5') BK	20

14 GA W/ BASEPLATE

CODE	QTY
2" x 14GA x 48" (4') BK with 5"x5" baseplate	20
2" x 14GA x 72" (6') BK with 5"x5" baseplate	20



11 GA POSTS

CODE	QTY
2" x 11GA x 72" (6') BK	70
2" x 11GA x 84" (7') BK	70
2" x 11GA x 96" (8') BK	70
2"x 11GA x 108" (9') BK	70
2" x 11GA x 120" (10') BK	70
2.5" x 11GA x 60" (5') BK	48
2.5" x 11GA x 72" (6') BK	48
2.5" x 11GA x 84" (7') BK	48
2.5" x 11GA x 96" (8') BK	48
2.5" x 11GA x 108" (9') BK	48
2.5" x 11GA x 120" (10') BK	48
2.5" x 11GA x 132" (11') BK	48
2.5" x 11GA x 144" (12') BK	48
3" x 3" x 11GA x 96" (8') BK	35
3" x 3" x 11GA x 108" (9') BK	35
3" x 3" x 11GA x 120" (10') BK	35
3" x 3" x 11GA x 132" (11') BK	35
3" x 3" x 11GA x 144" (12') BK	35
4" x 4" x 11GA x 96" (8') BK	20
4" x 4" x 11GA x 108" (9') BK	20
4" x 4" x 11GA x 120" (10') BK	20
4" x 4" x 11GA x 132" (11') BK	20
4" x 4" x 11GA x 144" (12') BK	20

11 GA W/ BASEPLATE

CODE	QTY
2" x 11GA x 60" (5') BK with 5" x 5" baseplate	20
2" x 11GA x 72" (6') BK with 5" x 5" baseplate	20
2.5" x 11GA x 60" (5') BK with 5" x 5" baseplate	20
2.5" x 11GA x 72" (6') BK with 5" x 5" baseplate	20

1/4 WALL HDG BLK

CODE	QTY
4" x 1/4 x 118" (10') HDG BK	12
5" x 1/4 x 118" (10') HDG BK	9
6" x 1/4 x 118" (10') HDG BK	6



GALVANIZED PIPE - 20WT + 40WT

20WT

1 7/8 20WT 8'

2 3/8 20WT 8'

2 7/8 20WT 8'

1 7/8 20WT 10'

2 3/8 20WT 10'

2 7/8 20WT 10'

40WT

1 7/8 40WT 8'

2 3/8 40WT 8'

2 7/8 40WT 8'

1 7/8 40WT 10

2 3/8 40WT 10

2 7/8 40WT 10

CHAINLINK MESH WIRE

CODE	QTY
2" 11GA GALV 6' K/K	50' ROLL
2" 11GA GALV 6' K/B	50' ROLL
2" 9GA GALV 6' K/K	50' ROLL
2" 9GA GALV 6' K/B	50' ROLL

COMPONENTS

CAPS - BLACK

1", 1.5", 2", 2.5", 3" and 4"

TEK SCREWS - BLACK

Tek Screws - 250 Per BOX

BRACKETS - BLACK



1.5" RES



1.5" COM



1" RES BIAS



1.5" COM BIAS



ZPOST

The Z Post is the best steel post for wood fencing on the market. Z Posts are durable, easy to use, and versatile. Wind rated up to 73 MPH, the same Z Post can be used for line posts, end posts, gate posts, and gate stops. Top to bottom staggered hole pattern allows for easy installation of kick boards, top caps, lattice work, and more.

- ☑ **SUPERIOR STRENGTH** - Wind rated up to 73 mph
- ☑ **DURABILITY** - Will not rot like traditional wood posts
- ☑ **EASY TO INSTALL** - No other brackets or hardware necessary
- ☑ **VERSATILE** - The same post can be used for corners and lines
- ☑ **ATTRACTIVE** - Can be easily concealed to blend in with your wood fence

PRODUCTS

7' Pre-Galvanized

8' Pre-Galvanized

9' Pre-Galvanized

8' Pre-Galv W/Brown Powder Coat

9' Pre-Galv W/Brown Powder Coat

10' Pre-Galv W/Brown Powder Coat

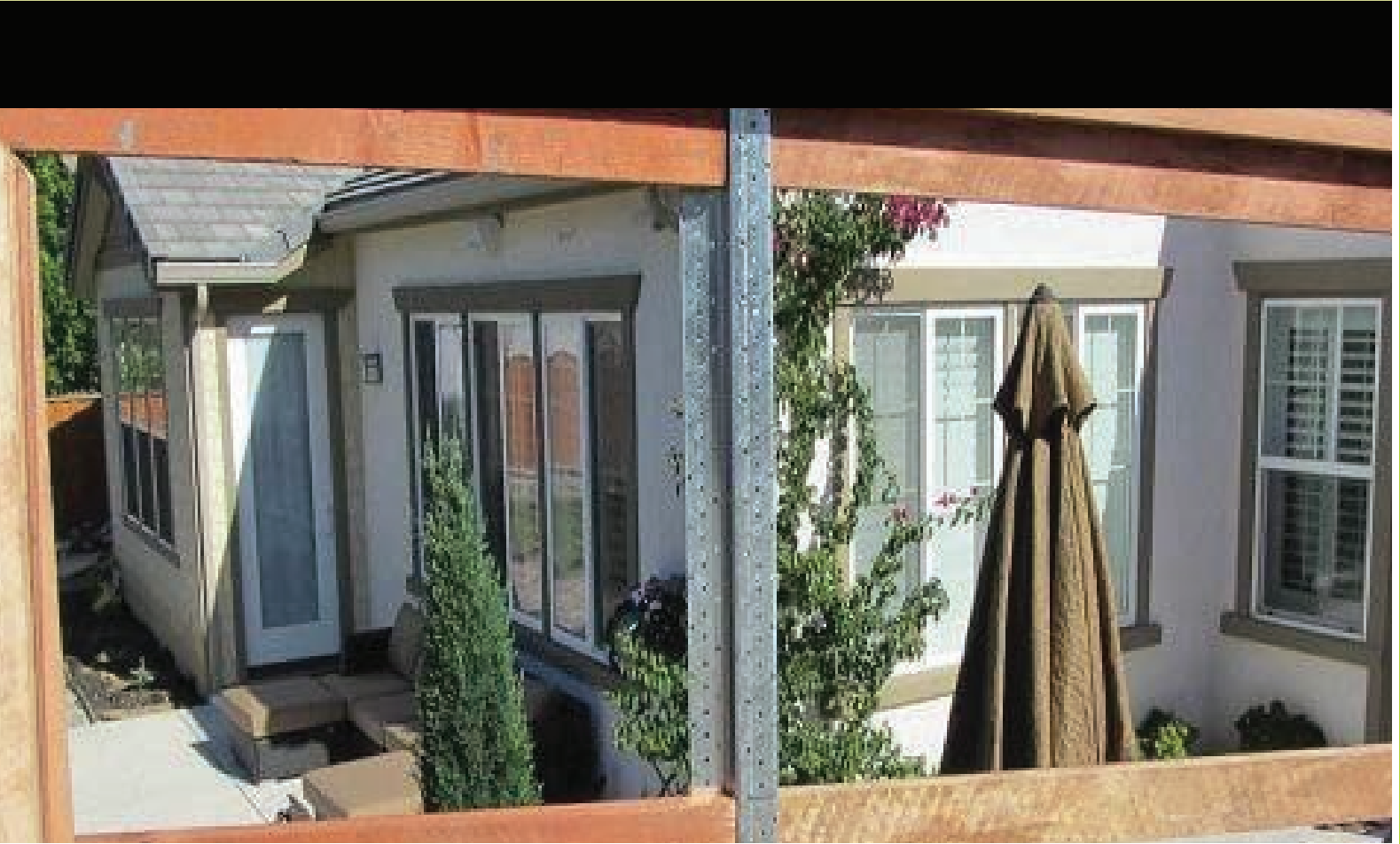



Safetech is a world-class designer and manufacturer of products that protect people and secure properties. Safetech specializes in innovative patented hardware products, assemblies and components. These include gate latches, safety locks, pool gate latches or heavy-duty hinges, self-closing hinges for gates made from aluminum, vinyl, timber and wrought iron, and other gate or fence hardware.

SAFETECH HARDWARE

Gate Hinges:

SHN-90L AlfaHINGE - Neutral Tension Gate Hinge

SHH-135LS MegaKLIK - Heavy Duty Adjustable Tension Hinge

SHH-135LS MegaKLIK - Heavy Duty Adjustable Tension Hinge

SHG-90L TopKLIK Adjustable Tension Hinge

SHF-90L Fix Tension Self Closing Hinge



SHN-90L AlfaHINGE -
Neutral Tension Gate Hinge



SHF-90L Fix Tension Self
Closing Hinge

Gate Latches:

SL-50H - 22" Lockable Magnetic Pool Gate Latch

SL-50KH - Keyless Magnetic Pool Gate Latch

SL-50H-TRI - TriLATCH Magnetic Pool Gate Latch

SL-25H 10" Magnetic Pool / Pedestrian Gate Latch

SLV-Viper-X2 VIPER Double Sided Gravity Latch (Key Alike)

SLV-Viper-X2 VIPER Double Sided Gravity Latch (Individual Keyed)

SLV-Viper-X1 VIPER Single Sided Gravity Latch

SDB-61-24 - 24" Drop Bolt

4" Wrap Around VIPER Latch

Gate Handle:

SHDL-150 Gate Handle

Gate Stops:

SGSS Gate Stop Small

SGSL Gate Stop Large

Metal Gate Latch

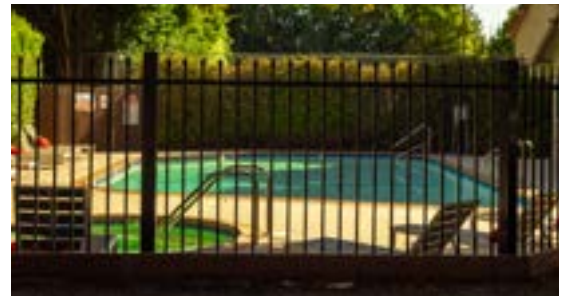
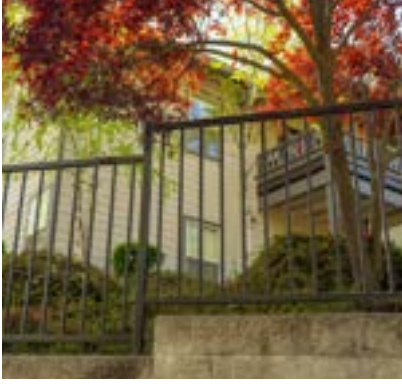

VANTAGE FENCE
STEEL FENCE WHOLESALER SUPPLIER

📍 4005 DEEBLE STREET
SACRAMENTO, CA 95820
☎ 888 - 291 - 4730
📞 SAC OFFICE: 916 - 720 - 5144
✉ EMAIL : ORDERS@VANTAGEFENCE.COM

